



TURNKEY BOILER BURNER SOLUTIONS



BURNERS

FLARES

INCINERATORS

PARTS & SERVICE

TURNKEY BOILER BURNER SOLUTIONS

Upgrading just got easier.

Whether you're converting a plant to natural gas to comply with new regulations, capitalizing upon an opportunity fuel for cost savings, or retrofitting your system with a new burner, you know the contract and upgrade process can be a real headache. Managing an array of system engineers and contractors, struggling to keep the project on time and on budget, and dealing with unpleasant surprises—all can result in significant business losses (not to mention more overtime for you).

Let Zeeco eliminate the hassles by assuming **single-point responsibility** for your combustion system upgrade. With a Zeeco OEM Turnkey Solution, there are no contractual layers between the customer, the OEM burner equipment supplier, and the contractors. It's a single team. A single vision. A singular commitment to your success. All backed by the engineering experience of the worldwide leader in combustion solutions.

Avoid burning time (and money).

With a Zeeco Turnkey Boiler Burner Solution, our dedicated project management team is responsible for all phases of the project, from engineering and designing the most cost-effective solution, to the equipment purchase process, through fabrication, testing, site supervision, installation, checkout, commissioning, and operator training.



Simply put, Zeeco eliminates the layers that can lead to lost time and cost overruns. Zeeco manages the engineering and design, equipment suppliers, and contract installation teams. We utilize your preferred local site contractors to perform the installation. Not only are they accessible and cost-effective, but they know your plant and procedures, and hold a vested interest in your long-term success.

ZEECO On-Site Training and Installation



Because all project phases are handled by one team, with a single vision, there are no shortcuts. No compromises. No disconnects. And with Zeeco "handling the details," your own resources—engineers, time and dollars—are available for other operational needs.

With a Zeeco turnkey solution, you will gain access to a single point of contact throughout the entire project and the full support of Zeeco, 24/7. You'll find this dramatically streamlines the process, condenses the timeframe, and results in a more cost-effective, transparent result.



Burner Management System Enclosure

GLSF Ultra-Low NO_x Free-Jet Boiler Burner



Fuel Valve Train System



Single-Point Responsibility

Zeeco's Turnkey Boiler Burner Solutions include:

- Design
- Engineering
- Safety Analysis and Assurance
- Contract Management
- Equipment Purchasing
- Fabrication
- Site Supervision
- Installation
- Checkout
- Commissioning
- Operator Training

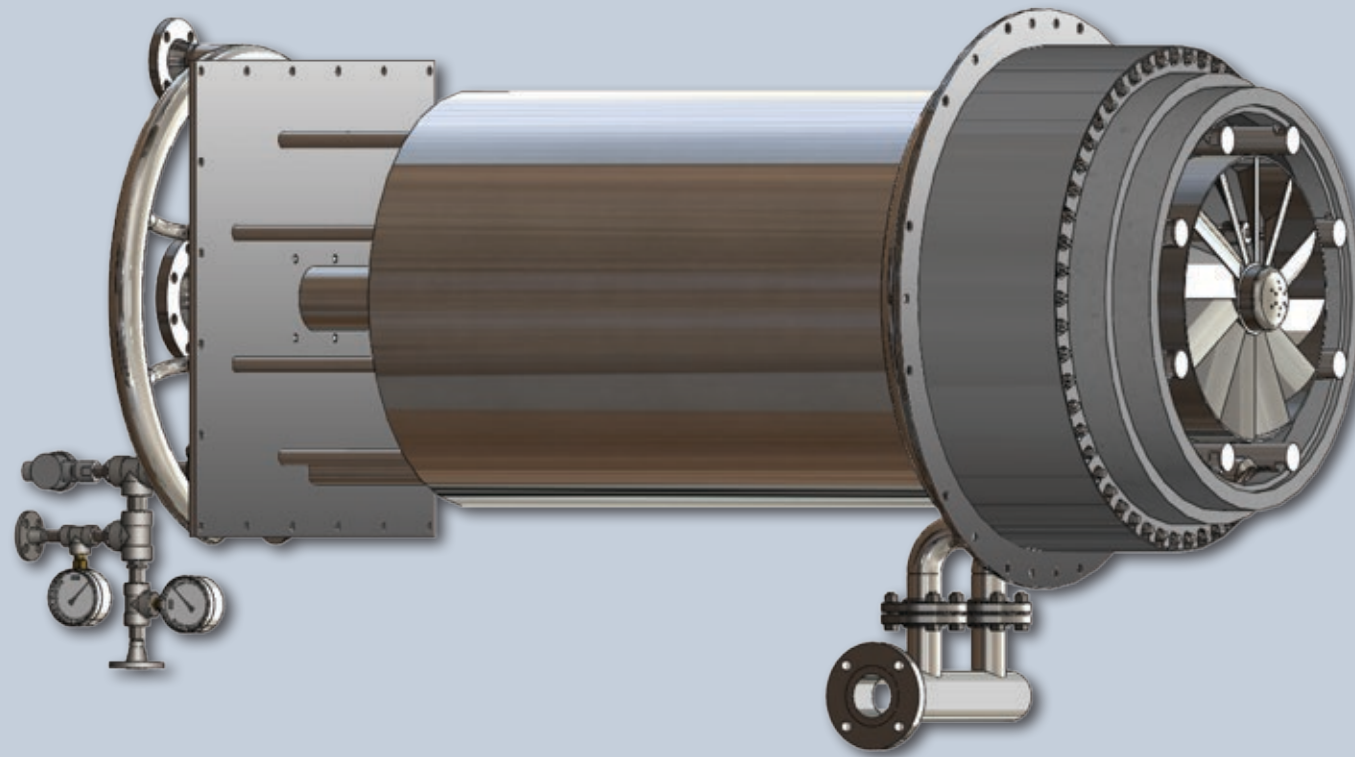

Our approach.

Each Zeeco turnkey solution begins with a pre-bid phase analysis, including a comprehensive site review. Our experienced team selects the ideal equipment and develops contractor bid specifications that detail every step of the project. The result is the most complete proposal in the industry, devoid of hidden, ongoing expenses that could otherwise lead to significant wasted expense and adders.

Once a contract is finalized and awarded, our team focuses on ensuring the project's success, down to the most intricate detail. Zeeco supplies all labor, on-site supervision, tools, equipment, consumables, safety equipment, piping, tubing, hangers, supports, structural steel, wiring, conduit, cable tray, junction boxes, and any other miscellaneous materials and support services required to complete the installation.

You will gain access to a Zeeco On-Site Project Manager whose job is to ensure the safe and proper installation of all equipment and to maintain the set project schedule. This manager will be your on-site contact from concept to commissioning. Following a complete system checkout, your Zeeco Project Manager will commission, and then turn over a fully operational system to you and your in-house team.

Better performance. Better results.

When you rely on Zeeco for our comprehensive turnkey service, you are spared the hassles of "minute-to-minute" oversight and can rest assured every detail is being monitored and addressed.

Zeeco's engineering team goes the extra mile on each and every boiler burner project, using state-of-the-art practices such as physical air flow modeling and advanced Computational Fluid Dynamics (CFD) to model your specific conditions against actual equipment design. With more stringent emissions regulations, it's critical to know where every pound of air and fuel enters the burner. A Zeeco turnkey solution will ensure you have the most effective burner design and meet or exceed all government regulations.

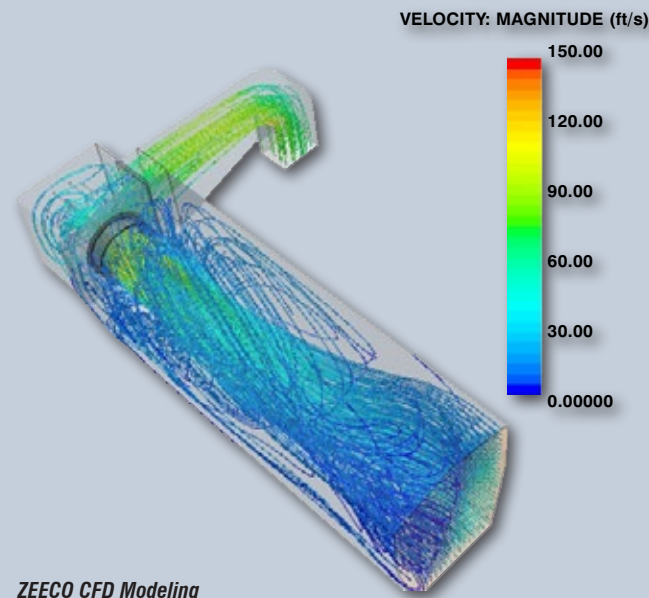

Zeeco's worldwide experience provides further assurance that we will be familiar with your project's requirements, regulations, and operating environment, wherever your facilities may be. From design to fabrication to installation, you can breathe easily knowing Zeeco is 100% committed to world-class safety practices.

With our turnkey projects being a true team effort, Zeeco offers worldwide combustion experience as you bring the full knowledge and understanding of your unique systems. Sharing your system's strengths and weaknesses allows us to better design a combustion system that performs on all fronts—not just those related to emissions.





The Zeeco difference.

Zeeco is the worldwide leader in combustion and environmental solutions. We are a privately held company with more than 20 global locations and thousands of installations to our name. Our Combustion Research and Test Facility is the largest and first in the world to become ISO 9001-2000 certified. With 21 test units (15 furnaces and 6 flares), Zeeco is capable of testing a wide variety of combustion systems under simulated field conditions.



ZEECO Combustion Research and Test Facility

We are confident you will thoroughly enjoy the many advantages of working with the flexible, innovative company that is Zeeco. Call or e-mail us today to request a quote or to learn more about our proprietary combustion systems.



ZEECO Headquarters on 250 acres (1 km²)



BURNERS



FLARES



THERMAL OXIDIZERS



PARTS & SERVICE



Zeeco Corporate Headquarters
 22151 East 91st Street
 Broken Arrow, Oklahoma 74014 USA
 Phone: +1 918 258 8551 Fax: +1 918 251 5519
 Email: sales@zeeco.com

Zeeco Connecticut
 80 Spring Lane
 Plainville, Connecticut 06062 USA
 Phone: +1 860 479 0999
 Email: zeeco_connecticut@zeeco.com

Zeeco.com



ZEECO® combustion and environmental solutions are designed and manufactured to comply with applicable local and international standards as defined by our customers.



REGISTERED
 ISO 9001: 2008

CERTIFICATIONS APPLY TO ZEECO HEADQUARTERS.

ZEECO® is a registered trademark of Zeeco, Inc. in the U.S.

● ZEECO office, affiliate, sales, representative, or third party representative/licensee offices.

© 2015 COPYRIGHT ZEECO, INC. ALL RIGHTS RESERVED